

Dimensions

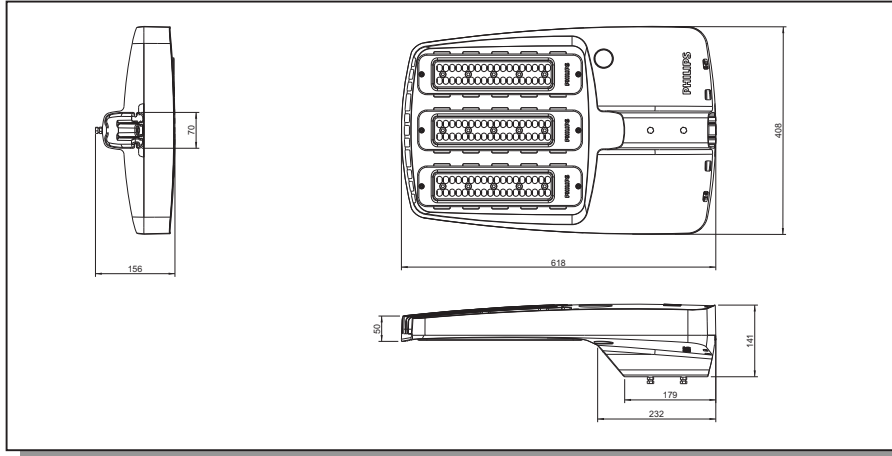

Installation

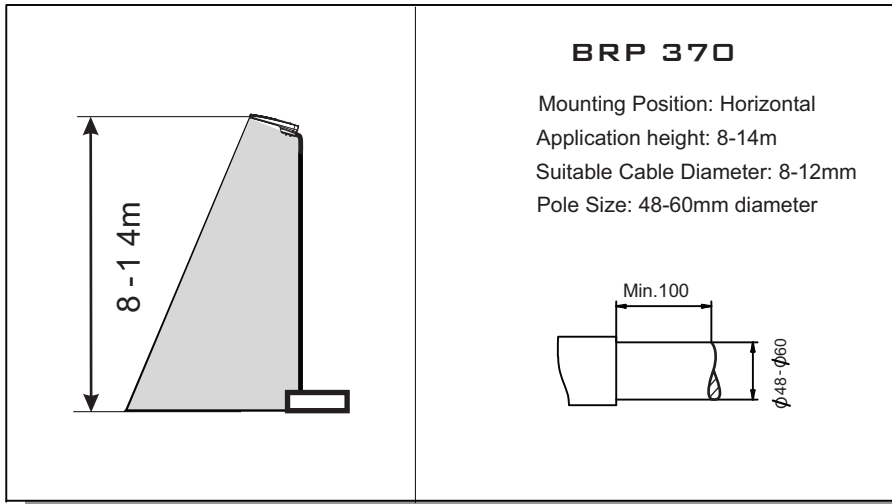

Installation Instruction

BRP 370

Street Lighting Luminaire

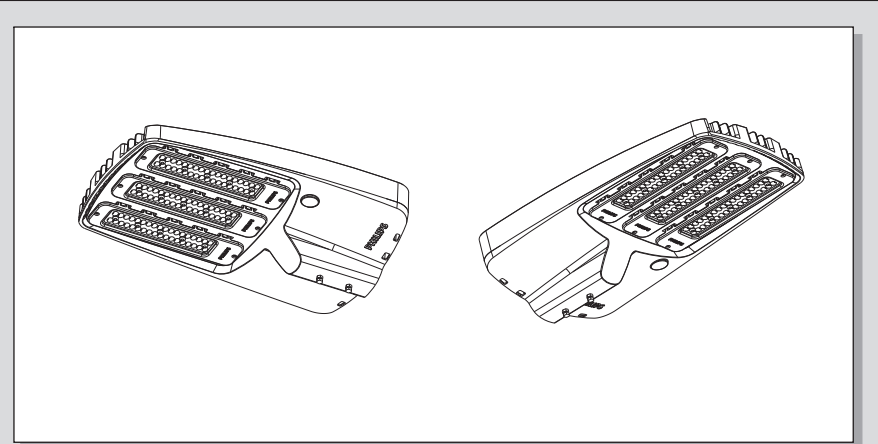

4415 109 27590

Type	:	BRP 370
Lamp	:	LED
Voltage	:	240 V, 50 Hz
IP Classification	:	IP 66
Net Weight	:	8.8 kgs
Max. Projected Area	:	0.233 m ²
Application	:	Outdoor use only

