

Installation Instruction

Dimensions

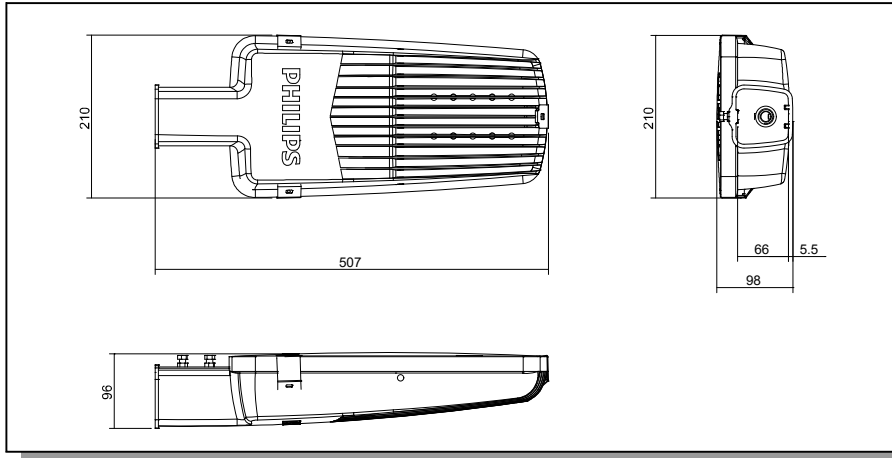

Installation

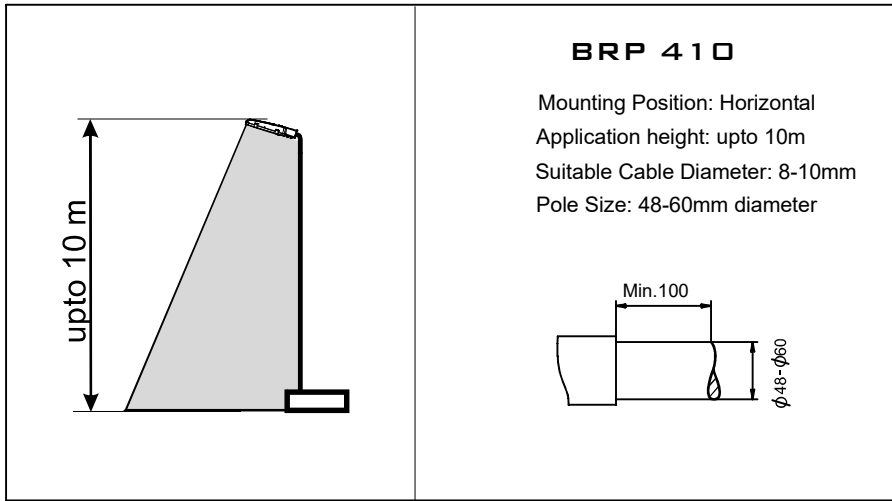

BRP 410

Street Lighting Luminaire

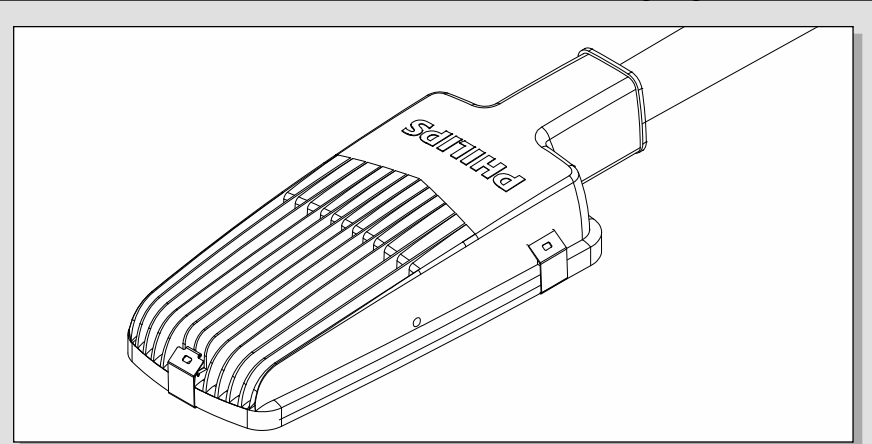

4415 109 27710

Type	:	BRP 410
Lamp	:	LED
Voltage	:	240 V, 50 Hz
IP Classification	:	IP 66
Net Weight	:	4.1kgs
Max. Projected Area	:	0.085 m ²
Application	:	Outdoor use only

1 Take the product out of the packing box.

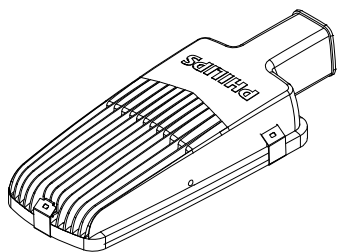

2 Open the toggles using screw drivers by pulling as shown.

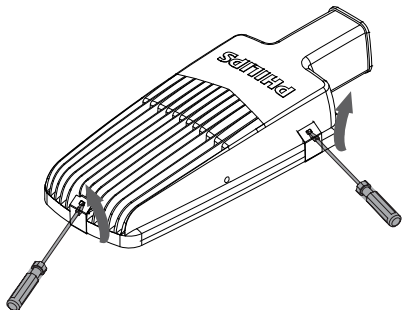

7 Make the electrical connections as per the LN marking

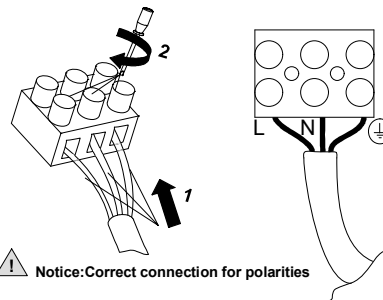

⚠ Notice: Correct connection for polarities

8 Put the front cover in position and fix the toggles.

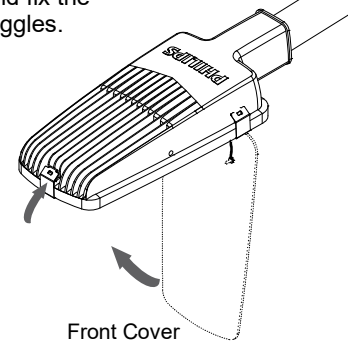

3 The front Cover will open as shown.

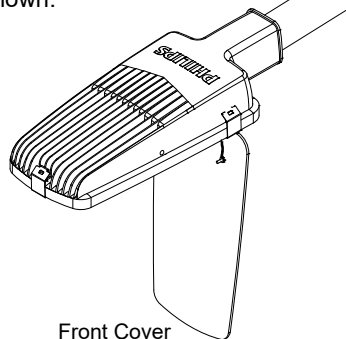

4 Allow the incoming cable to pass through the gland and tighten it with spanner

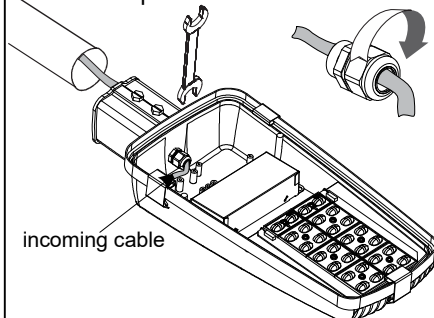

9 Luminaire is ready for use.

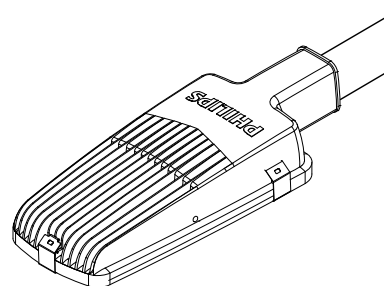

10



CAUTION: Broken Glass/
front diffusers should be
immediately replaced.

5 Fix the street light over the pole and tighten the bolts.
Tightening Torque: 8Nm

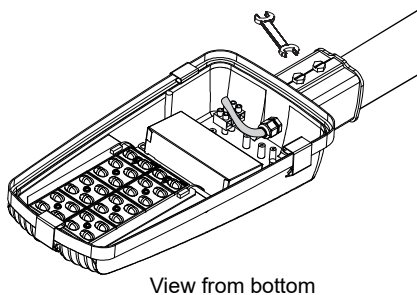

6 Cut the wire as per the size with wire cutter

